

2. A large-amplitude ramp waveform provides good noise margin for a stable modulation process.
3. A low-impedance power output provides better cross-regulation for multiple output supplies.

Voltage-mode's disadvantages can be listed as:

1. Any change in line or load must first be sensed as an output change and then corrected by the feedback loop. This usually means slow response.
2. The output filter adds two poles to the control loop requiring either a dominant-pole low frequency roll-off at the error amplifier or an added zero in the compensation.
3. Compensation is further complicated by the fact that the loop gain varies with input voltage.

Current Mode Control

The above disadvantages are relatively significant and since all are alleviated with current-mode control, designers were highly motivated to consider this topology upon its introduction. As can be seen from the diagram of Figure 2, basic current-mode control uses the oscillator only as a fixed-frequency clock and the ramp waveform is replaced with a signal derived from output inductor current.

The advantages which this control technique offers include the following:

1. Since inductor current rises with a slope determined by $V_{in}-V_o$, this waveform will respond immediately to line voltage changes, eliminating both the delayed response and gain variation with changes in input voltage.
2. Since the Error Amplifier is now used to command an output current rather than voltage, the effect of the output inductor is minimized and the filter now offers only a single pole to the feedback loop (at least in the normal region of interest). This allows both simpler compensation and a higher gain bandwidth over a comparable voltage-mode circuit.
3. Additional benefits with current-mode circuits include inherent pulse-by-pulse current limiting by merely clamping the command from the Error Amplifier, and the ease of providing load sharing when multiple power units are paralleled.

While the improvements offered by current-mode are impressive, this technology also comes with its own unique set of problems which must be solved in the design process. A listing of some of these is outlined below:

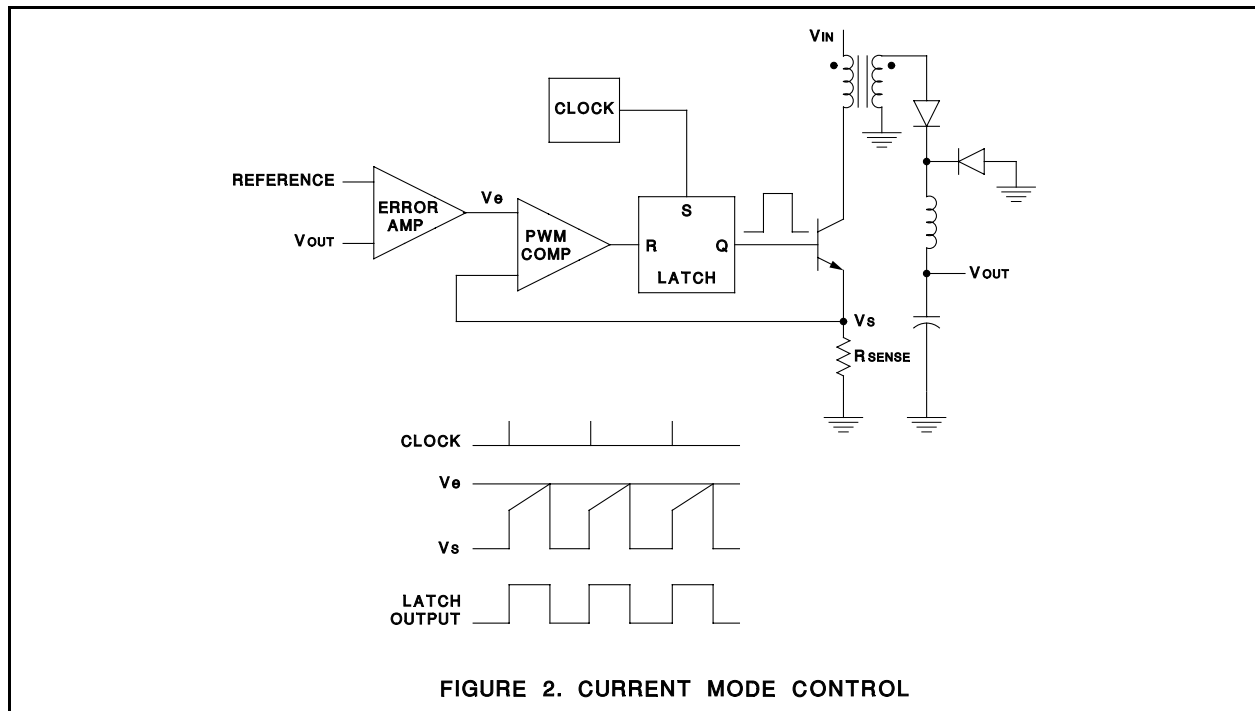

FIGURE 2. CURRENT MODE CONTROL

Figure 2. Current Mode Control

1. There are now two feedback loops, making circuit analysis more difficult.
2. The control loop becomes unstable at duty cycles above 50% unless slope compensation is added.
3. Since the control modulation is based on a signal derived from output current, resonances in the power stage can insert noise into the control loop.
4. A particularly troublesome noise source is the leading edge current spike typically caused by transformer winding capacitance and output rectifier recovery current.
5. With the control loop forcing a current drive, load regulation is worse and coupled inductors are required to get acceptable cross-regulation with multiple outputs.

So from the above we can conclude that while current-mode control will ease many of the limitations of voltage-mode, it also contributes a new set of challenges to the designer. However, with the knowledge gained from more recent developments in power control technology, a re-evaluation of voltage-mode control indicated that there were alternative ways to correct its major weaknesses and the result was the UCC3570.

Voltage-Mode Revisited

The two major improvements to voltage-mode control offered by the UCC3570 are voltage feed-forward to eliminate the effects of line voltage variations, and higher frequency capability which allow the poles of the output filter to be placed above the range of normal control loop bandwidth.

Voltage feed-forward is accomplished by making the slope of the ramp waveform proportional to input voltage. This provides a corresponding and correcting duty cycle modulation with no action needed by the feedback loop. The result is a constant control loop gain and instantaneous response to line voltage changes. The higher frequency capability is accomplished through the use of BiCMOS processing for this IC which yields smaller parasitic capacitance and lower circuit delays. Thus many of the problems of voltage-mode have been alleviated without incurring the difficulties of current-mode.

Choosing Circuit Topologies

None of the above discussion should leave the impression that there is no longer a place for

current-mode control - only that both topologies are viable choices in today's environment. There are considerations which could point to one or the other as more optimum for each particular application. Some of these are outlined below:

Consider the use of current-mode if:

1. The power supply output is to be a current source or very high output voltage.
2. The fastest dynamic response is needed with a given switching frequency.
3. The application is for a DC/DC converter where the input voltage variation is relatively constrained.
4. Modular applications where parallelability with load sharing is required.
5. In push-pull circuits where transformer flux balancing is important.
6. In low-cost applications requiring the absolute fewest components.

Consider voltage-mode (with feed-forward) if:

1. There are wide input line and/or output load variations possible.
2. Particularly with low line - light load conditions where the current ramp slope is too shallow for stable PWM operation.
3. High power and/or noisy applications where noise on the current waveform would be difficult to control.
4. Multiple output voltages are needed with relatively good cross-regulation.
5. Saturable reactor controllers are to be used as auxiliary secondary-side regulators.
6. Applications where the complexities of dual feedback loops and/or slope compensation is to be avoided.

In line with these considerations, the UCC3570 has been optimized for low-to-medium power, off-line, primary-side control applications with isolated feedback. It features many performance enhancements for this task in addition to the control characteristics described above but, since that is not the purpose of this document, the reader is referred to the product data sheet for further information.

Reprinted with permission from Electronic Design, June 27, 1994. Copyright 1994, Penton Publishing Inc.